



# DUODISK TECHNICAL PROCEDURES

## TABLE OF CONTENTS

### Section 1. Troubleshooting

General Information.....	1.2
Using the Troubleshooting Flowchart.....	1.2
Troubleshooting Flowchart.....	1.3
Chip Swapping Chart.....	1.4

### Section 2. Adjustments

D-Speed Test and Adjustment.....	2.2
----------------------------------	-----

### Section 3. Take-Apart

Removing the Cover and Shield.....	3.2
Removing the Analog Card .....	3.3
Removing the Mechanical Assembly.....	3.3
Replacing the Mechanical Assembly.....	3.4
Replacing the Analog Card.....	3.4
Replacing the Shield and Cover.....	3.5

### Section 4. Illustrated Parts List

Illustrated Parts List and Diagrams.....	4.1
--	-----

### Appendix A. Special Repair Procedure for Loose Boards

Background.....	A.1
Procedure.....	A.1

©Apple Computer, Inc., 1985.  
No part of this document may be reproduced in any form  
without the written permission of Apple Computer, Inc.

DuoDisk is a trademark of Apple Computer, Inc.  
Apple and the Apple logo are registered trademarks of  
Apple Computer, Inc.





## Duodisk Technical Procedures

### Appendix A

#### SPECIAL REPAIR PROCEDURE FOR LOOSE ANALOG BOARDS

(DUODISKS WITH SERIAL NUMBER BELOW 325000)

#### BACKGROUND

On some Duodisks with serial numbers before 325000, the analog board is too loose and may slip out of its guide track (the forward supports on the sides of the shield - see Figure 1, #1, next page). This brings the analog board into contact with the disk mechanical assembly and may short circuit the board when power is applied. Where this condition exists, the sides of the shield must be bent inward slightly to prevent the board from falling. This document contains the procedure.

(This is a low-level problem, mostly limited to Duodisks found "dead on arrival". Apple has already upgraded the inventory of Duodisks with serial numbers of 325000 and above.)

#### PROCEDURE

1. Check the serial number of the Duodisk: If it is below 325000, continue with this procedure.
2. Check to see if the board has slipped out of the guide track and if transistor Q2 on the front of the old board has blown (the damage will be visible.) If so, continue with this procedure.
3. If Q2 has blown, or if the board is otherwise bad, replace the bad analog board with a good board.

If the board has not blown but has a visible tendency to fall off its supports, you should also perform this procedure.

CONTINUED ON NEXT PAGE

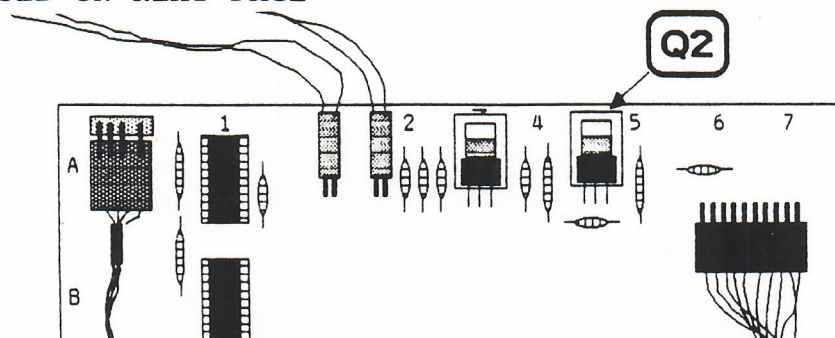

4. Using needlenose pliers, bend the top of the shield inward about 1 mm., so that the guides hold the analog board firmly in place (see Figure 1, #1).

**IMPORTANT:** Do not bend the shield too far, as any stress on the mechanical assembly may cause problems with the head radial adjustment.

5. Run the Drive Acceptance Program (DAP) tests, to check for possible head radial adjustment problems due to stress on the mechanical assembly. If you find such problems, bend the shield back until they no longer occur. If the drive continues to fail the DAP, send it back to Apple for repair.
6. Look through the disk drive door to make sure that the analog board is seated correctly. If the analog board still shows a tendency to fall off its supports, repeat steps 4-6.

Top View of Shield, Drive 1

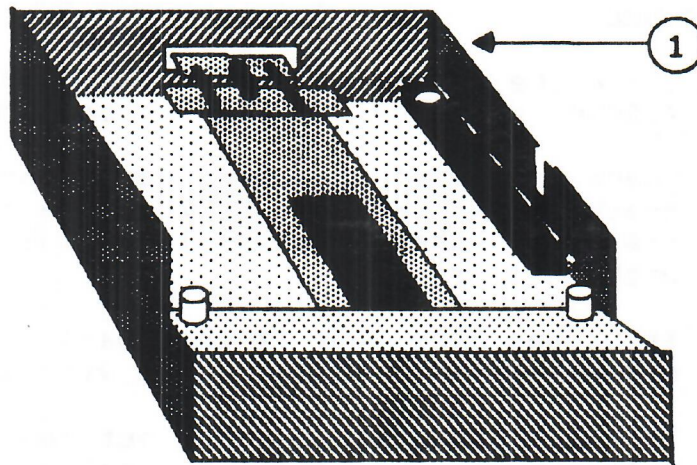

Figure 1



# Duodisk Technical Procedures

## Appendix B

### Illustrated Parts List

#### Contents

Duodisk.....	B.2
Duodisk.....	B.3





The figures and lists below include all piece parts that can be purchased separately from Apple for the Duodisk™ disk drive along with their part numbers. Refer to your Apple Service Programs binder for prices.

Duodisk (Figure 1)

Item	P/N	Description
1	400-1604	Screw 6-32x1/4
2	805-5002	Shield, Top, Drive 2
3	676-5101	Subassembly, Bottom Cover
4	805-5000	Shield, Bottom, Duodisk
5	805-5003	Shield, Mounting, Drive 1
6	676-5103	Top Cover Assembly
7	415-1410	Screw
8	590-0114	Assembly Cable, DB-19 to Disk

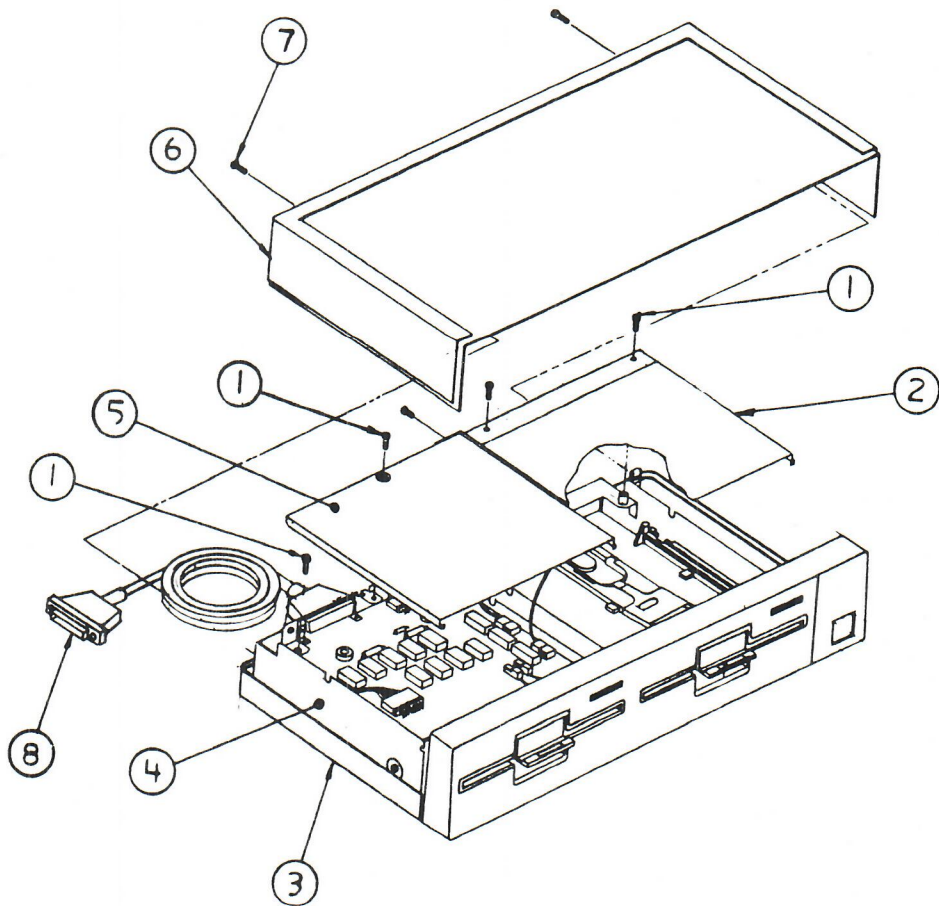

Duodisk (Figure 2)

Item	P/N	Description
1	U815-0064	Load Button
2	590-0140	Assembly, Cable, LED, D1
3	870-0023	Spring
4	590-0223	Cable Assembly LED
5	400-1604	Screw 6-32x1/4
6	415-1410	Screw
7	860-0242	Washer, M3.5x4.0 I.D. x7.0 O.D
8	860-0053	Washer, Split Lock Metric, M3.5
9	661-72128	Disk Mechanical Assembly
10	805-5029	Seat Insulating
11	805-5028	Shield Plate
12	661-92130	Analog Card, Duodisk

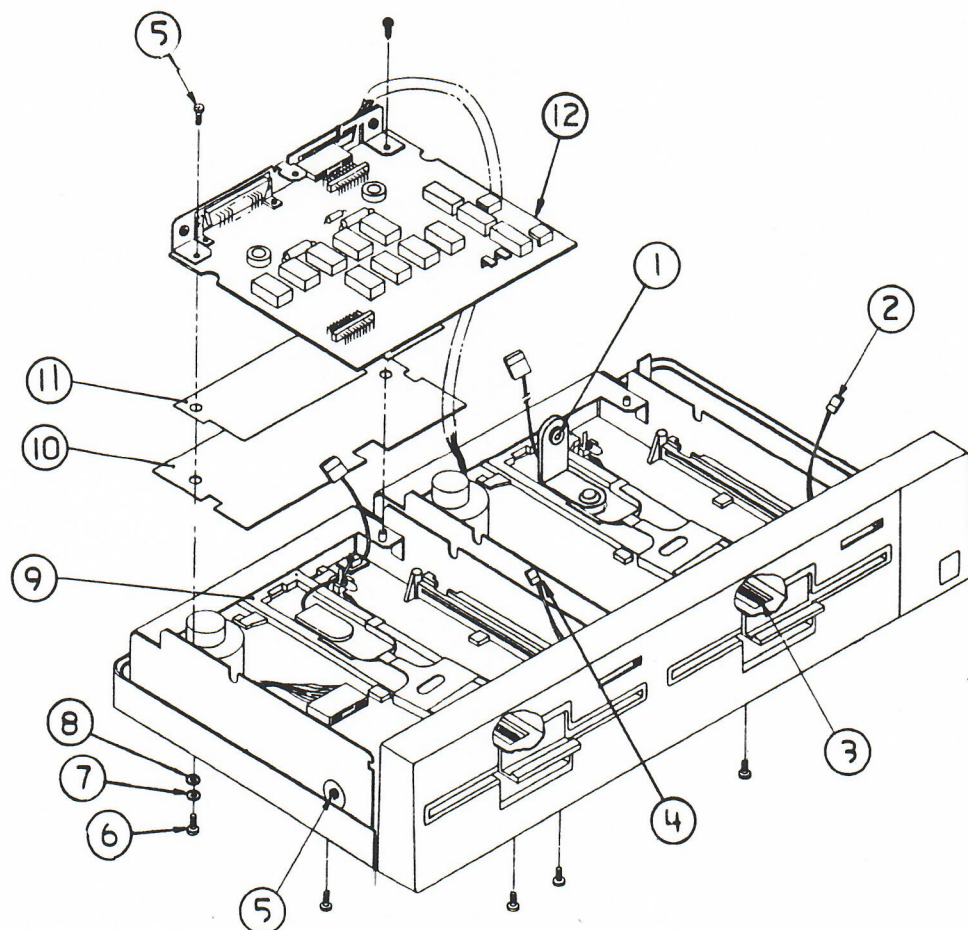







# DuoDisk Technical Procedures

## Section 1

### Troubleshooting

#### Contents:

General Information.....	1.2
Using the Troubleshooting Flowchart.....	1.2
Troubleshooting Flowchart.....	1.3
Chip Swapping Chart.....	1.4



## General Information

The Apple® DuoDisk™ disk drive is effectively two disk drives in one case. Both drives are attached to a single analog card, with the drive on the left side defined as Drive 1.

There are four main modules which can be replaced: the interface card, the interface cable, the analog card, and the mechanical assembly. Chip swapping on the analog card is recommended before replacing the card.

## Using the Troubleshooting Flowchart

Whenever a customer brings in a presumably bad Duodisk, use the flowchart on the following page to begin troubleshooting. Begin with the box in the upper left corner of the page. When you get to one of the answer boxes (boxes with dark borders), swap the modules/components, one at a time, in the order in which they are listed. Each time you swap out a module/component, turn on the computer and see if you can boot a system diskette (preferably the DOS 3.3 System Master).

Remember, once you are able to boot a diskette, be sure to run the Drive Acceptance Program (P/N 077-8101A) performing any adjustments necessary. Reinstall the customer's modules/components, one at a time, testing after each exchange to isolate the bad part(s).

**NOTE:** There is a chance for data on the diskette to be lost in operating the DuoDisk. This can occur in attempting the "Open Apple CTL-Reset" technique for rebooting, or when using software with certain copyright protection schemes. If a unit exhibits this problem and passes the Drive Acceptance Program, check the analog board. Analog boards with part numbers 676-[]101 and 676-[]102 may have this problem. The fix is to carefully identify and cut two capacitors off the board. The capacitors are labeled C29 and C30 in zones B1 and A1 (refer to the DuoDisk Analog Card Chip Swapping Chart and Figure 1, #4 and #5). Use small wire clippers or simply jiggle the capacitors to snap the connections.

**NOTE:** If you do not know how to connect the DuoDisk to an Apple computer, refer to the DuoDisk Owner's Manual for instructions.



# DUODISK TROUBLESHOOTING FLOWCHART

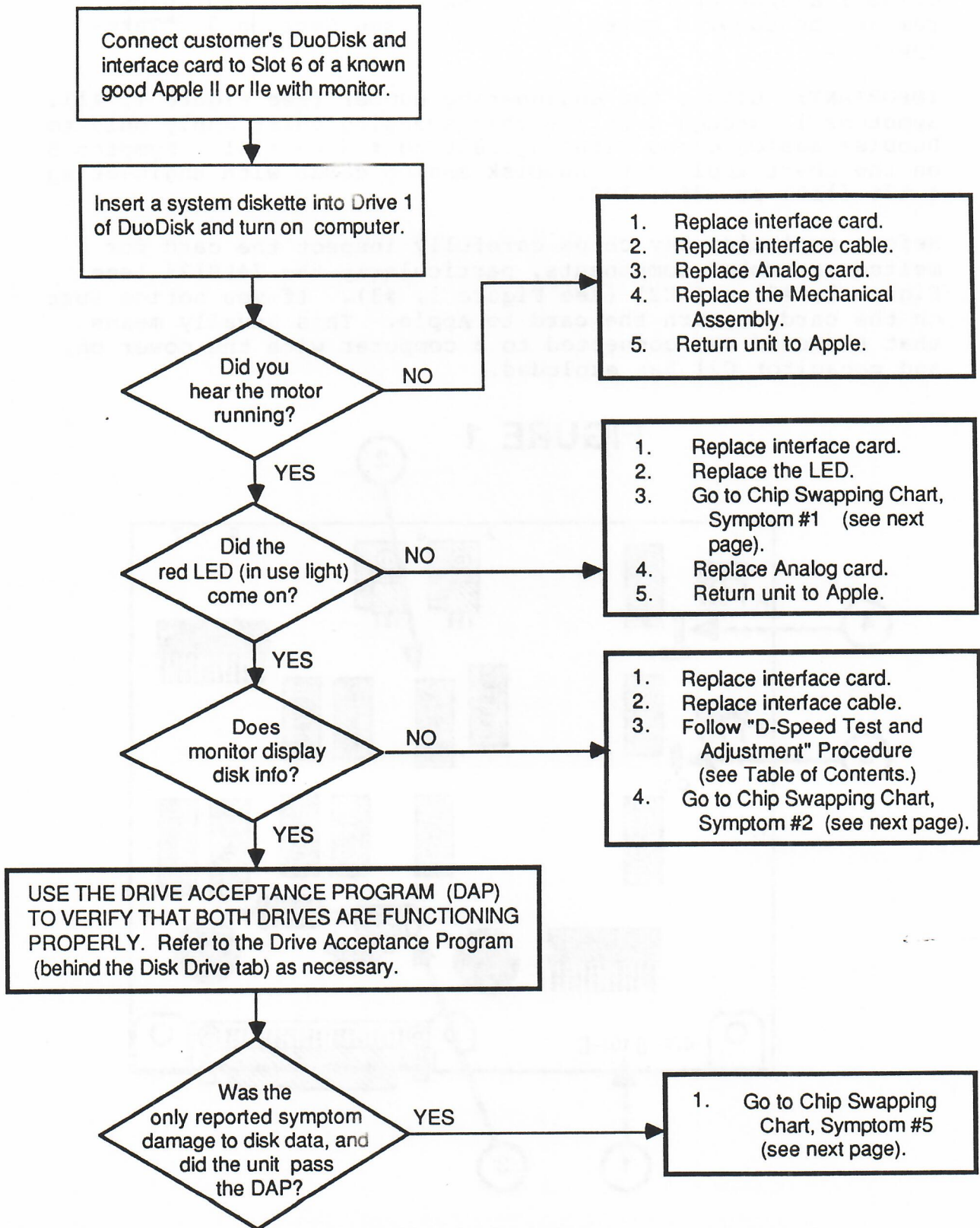



## DuoDisk Analog Card Chip Swapping Chart

The chip swapping chart on the opposite page can be used for drive 1 and/or drive 2. To access the analog card chips, remove the DuoDisk cover and shield (see Section 3, "Take-Apart").

**IMPORTANT:** Locate the engineering number (see Figure 1, #1). Symptoms 1 through 4 on the chip swapping chart apply only to DuoDisk analog cards with Engineering # 676-[]101. Symptom 5 on the chart applies to DuoDisk analog cards with Engineering # 676-[]101 or 676-[]102.

Before replacing any chips carefully inspect the card for melted or broken components, particularly the 74LS125 (see Figure 1, #2) and C21 (see Figure 1, #3). If you notice fuzz on the card, return the card to Apple. This usually means that the card was connected to a computer with the power on, and capacitor C21 has exploded.

### FIGURE 1

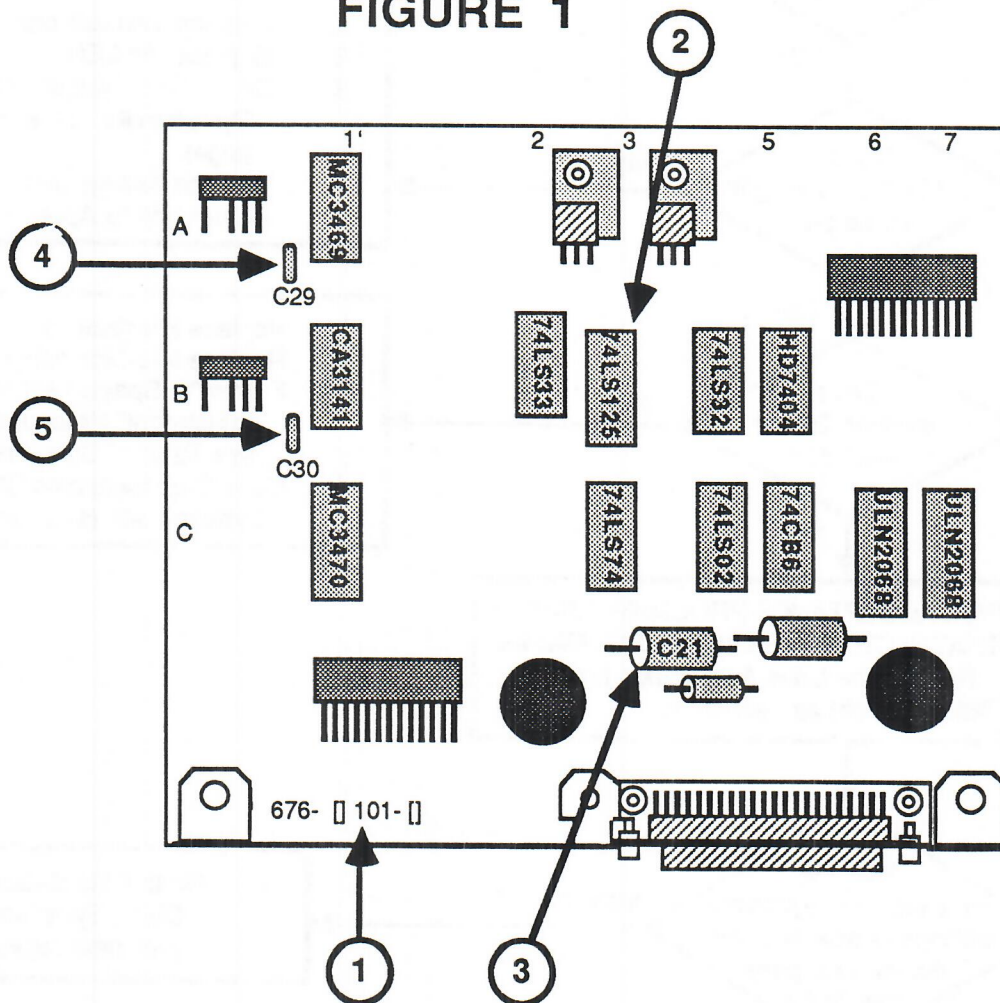



## Here's What To Do

Identify the symptom and replace the related chips, one at a time, in the order in which they are listed. Each time you replace a chip, turn the computer back on to see if the problem is gone. If the problem still exists after you have replaced all the chips related to the problem, go to the next step listed in the answer box (where you left off) on the troubleshooting flowchart.

Symptom	Location	Defective Chip Type	
1. Motor runs, but LED is off	A1	3469	
	B4	74LS32	
	B5	74LS07	
Won't boot			
2. Motor and LED are on	B1	CA3141	
	B3	74LS125	
	A1	MC3469	
	C1	MC3470	
	Won't boot	B2	74LS33
	B5	7407	
	C3	74LS74	
	C4	74LS02	
	C6	ULN2068	
C7	ULN2068		
3. Drive reads but does not write	A1	MC3469	
	B1	CA3141	
	B2	74LS33	
	B3	74LS125	
	C5	74C86	
	B5	7407	
4. Drive writes when diskettes are write protected	A1	MC3469	
5. Data on disk is damaged when using "Open Apple-CTL-Reset" for rebooting, or when using software with certain copyright protection schemes.	A1	Capacitor C29	
	B1	Capacitor C30	
		(remove both, do not replace)	
<u>AND: Unit passes DAP.</u>			
<u>AND: Analog board PN is 676-[]101 or 676-[]102.</u>			





## DuoDisk Technical Procedures

### Section 4

#### Illustrated Parts List

The figures and lists below include all piece parts that can be purchased separately from Apple for the DuoDisk, along with their part numbers. These are the only parts available from Apple. Refer to your Apple Service Programs manual for prices.

#### Contents:

Illustrated Parts List.....	4.1
-----------------------------	-----

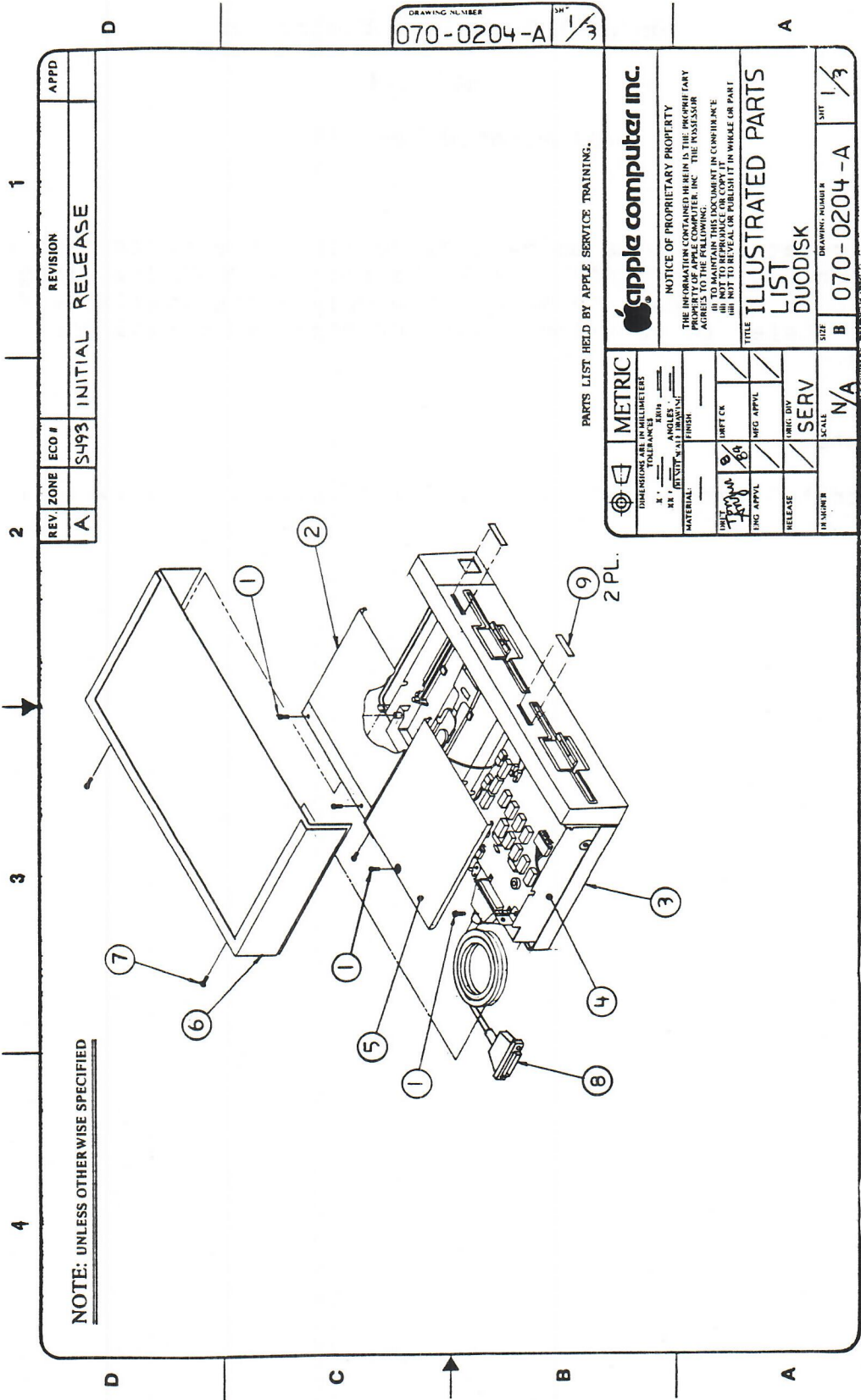

NOTE: UNLESS OTHERWISE SPECIFIED

REV. ZONE	ECO #	REVISION	APPD
A	S493	INITIAL RELEASE	

DRAWING NUMBER 070-0204-A <sup>SHT</sup> 1/3

PARTS LIST HELD BY APPLE SERVICE TRAINING.

METRIC DIMENSIONS IN MILLIMETERS TAPE DIMENSIONS IN MILLIMETERS Holes in Millimeters Holes in Inches FINISH		NOTICE OF PROPRIETARY PROPERTY THE INFORMATION CONTAINED HEREIN IS THE PROPRIETARY PROPERTY OF APPLE COMPUTER, INC. THE POSSESSOR AGREES TO THE FOLLOWING: (i) TO MAINTAIN THIS DOCUMENT IN CONFIDENCE (ii) TO REPRODUCE THIS DOCUMENT ONLY FOR PERSONAL USE (iii) NOT TO REVEAL OR PUBLISH IT IN WIRKLE OR PART
MATERIAL DRIFT CK TNC APPVL RELEASE TR SURFR		
TITLE ILLUSTRATED PARTS LIST DUODISK		DRAWING NUMBER 070-0204-A <sup>SHT</sup> 1/3
SCALE N/A		





**DUODISK (Figure 1)**

<b>Item</b>	<b>Part No.</b>	<b>Description</b>
1	400-1604	Screw, 6-32x1/4
2	805-5002	Shield, Top, Drive 2
3	676-5101	Subassembly, Bottom Cover
4	805-5000	Shield, DuoDisk
5	805-5001	Shield, Top, Drive 1
6	676-5103	Top Cover Assembly
7	415-1410	Screw, M3.5x6x10MM. PN
8	590-0114	Duodisk Cable
9	825-0548	Label, Drive #, Uni/DuoDisk



REV. ZONE	ECR #	REVISION	APPD

**NOTE: UNLESS OTHERWISE SPECIFIED**

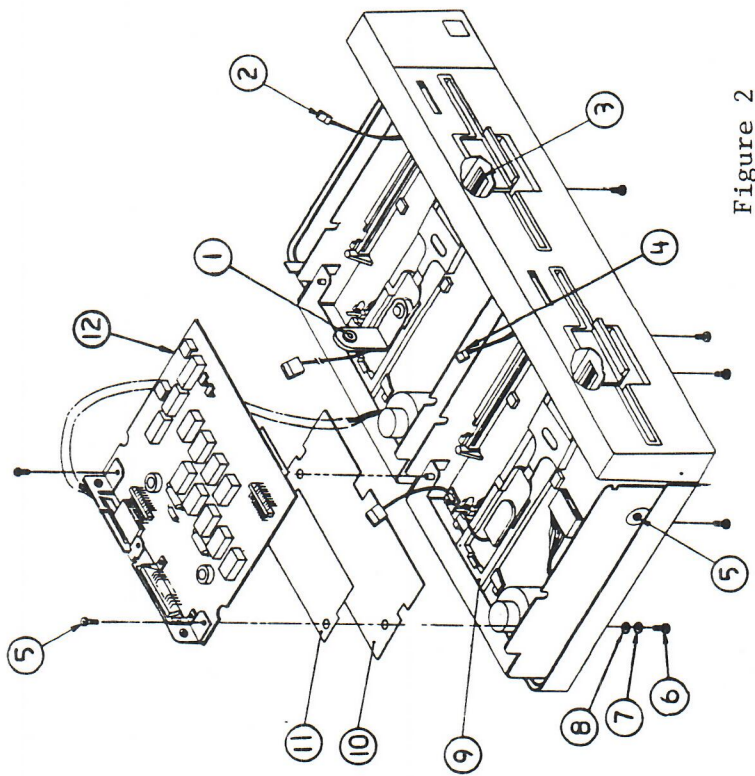
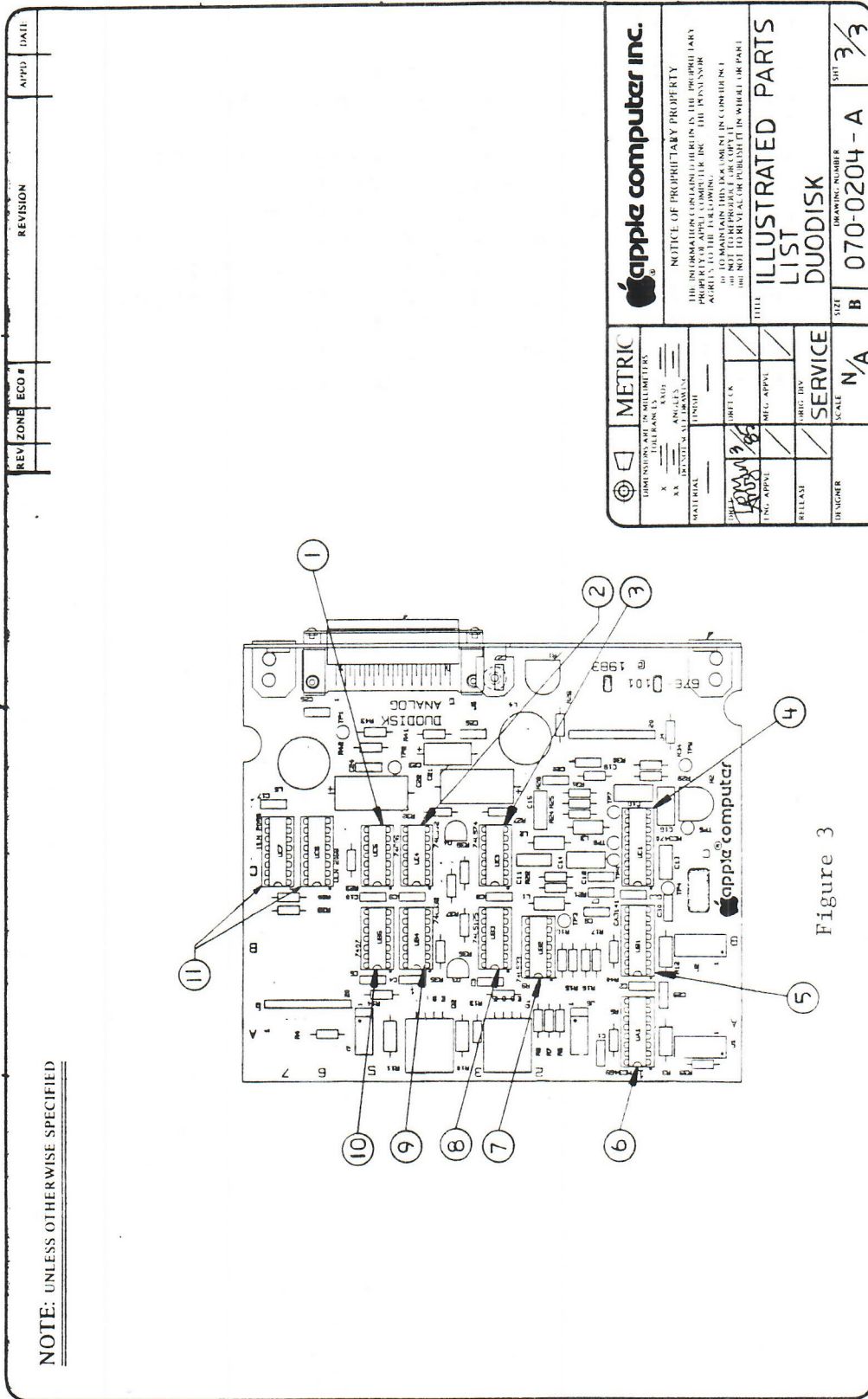

Figure 2

<b>METRIC</b> DIMENSIONS ARE IN MILLIMETERS TOLERANCES FINISH:		<b>Apple computer inc.</b>	
MATERIALS: 1. 6061-T6 ALUMINUM 2. 6061-T6 ALUMINUM 3. 6061-T6 ALUMINUM 4. 6061-T6 ALUMINUM 5. 6061-T6 ALUMINUM 6. 6061-T6 ALUMINUM 7. 6061-T6 ALUMINUM 8. 6061-T6 ALUMINUM 9. 6061-T6 ALUMINUM 10. 6061-T6 ALUMINUM 11. 6061-T6 ALUMINUM 12. 6061-T6 ALUMINUM		NOTICE OF PROPRIETARY PROPERTY THE INFORMATION CONTAINED HEREIN IS THE PROPRIETARY PROPERTY OF APPLE COMPUTER, INC. THE POSSESSOR AGREES TO THE FOLLOWING: I. TO MAINTAIN THIS DOCUMENT IN CONFIDENCE II. NOT TO REPRODUCE OR COPY IT III. NOT TO REVEAL OR PUBLISH IT OR WHOLE OR PART	
TITLE ILLUSTRATED PARTS LIST DUODISK		DRAWING NUMBER 070-0204 - A	
SCALE N/A		SHEET 2 / 3	

DUODISK (Figure 2)

1	U815-0064	Load Button
2	590-0223	Assembly, Cable, LED, D2
3	870-0023	Spring
4	590-0140	Assembly, Cable, LED, D1
5	400-1604	Screw, 6-32x1/4
6	415-1410	Screw, M3.5x6x10MM. PN
7	860-0242	Washer, M3.5x4.0 I.D.x7.0 O.D.
8	860-0053	Washer, Split Lock Metric, M3.5
9	661-72128	Duodisk Disk Mech. Assembly
10	805-5028	Shield Plate
11	805-5029	Seat Insulating
12	661-92130	Duodisk Analog Card





**DUODISK ANALOG CARD (Figure 3)**

1	322-0086	IC, 74C86
2	306-0002	IC, 74LS02
3	305-0074	IC, 74LS74
4	355-3470	IC, MC3470 Floppy Disk Read Ampl.
5	352-3141	IC, Hi Voltage Diode Diode 30V, 100 mA
6	331-3469	IC, 3469 Floppy Disk Write Cont.
7	305-0033	IC, 74LS33
8	306-0125	IC, 74LS125
9	305-0032	IC, 74LS32
10	302-0007	IC, 7407
11	351-2068	IC, 1.5A Darlington

